

# BPV 500

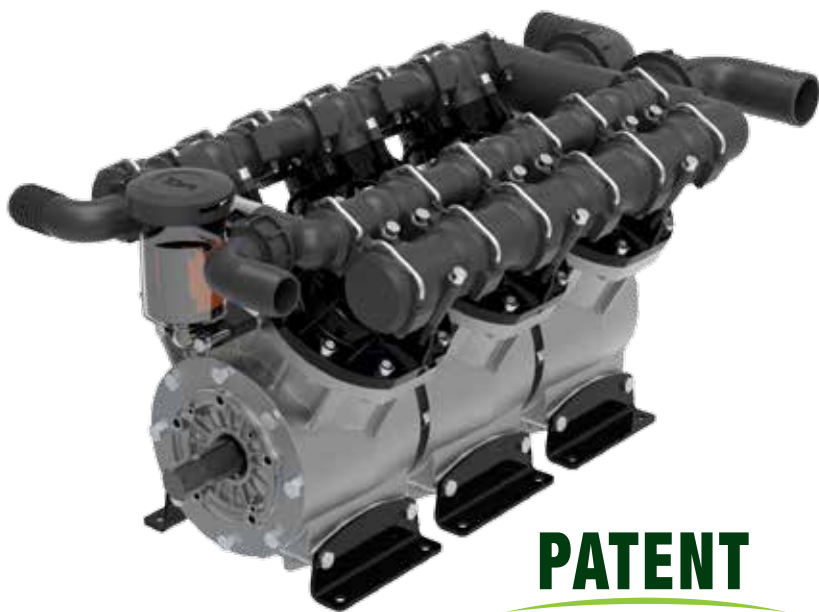

POMPE A MEMBRANA A BASSA PRESSIONE  
LOW PRESSURE DIAPHRAGM PUMPS  
POMPES A MEMBRANE A BASSE PRESSION  
BOMBAS A MEMBRANA DE BAJA PRESION  
NIEDERDRUCK-MEMBRANPUMPEN



**PATENT  
PENDING**



- ★ Cover protettiva su richiesta.
- ★ Protective cover on request.
- ★ Capot de protection à la demande.
- ★ Capó de protección bajo pedido.
- ★ Schutzabdeckung auf Wunsch.

Configurazione: 6 membrane in Desmopan®. Parti a contatto con il liquido: alluminio plastificato e poliammide. A richiesta: valvola di sicurezza, protezione p.d.f. Design estremamente compatto grazie alla configurazione brevettata a V.

Configuration: 6 diaphragms in Desmopan®. Parts in contact with spray liquid: plastic coated aluminium and polyamide. On request: safety valve and PTO protection. A highly compact design thanks to the patented V construction.

Configuration: 6 membranes en Desmopan®. Parties au contact du liquide : aluminium plastifié et polyamide. À la demande : soupape de sécurité, protection prise de force. Un design extrêmement compact grâce à la configuration en V brevetée.

Configuración: 6 membranas en Desmopan®. Partes en contacto con el líquido: aluminio plastificado y poliamida. Bajo pedido: válvula de seguridad, protección toma de fuerza (t.d.f.). Diseño extremadamente compacto gracias a la configuración patentada en V.

Konfigurierung: 6 Membranen aus Desmopan®. Teile im Kontakt mit der Flüssigkeit: plastifiziertes Aluminium und Polyamid. Auf Wunsch: Sicherheitsventil und Zapfwellenschutz. Extrem kompaktes Design dank der patentierten V-Konfiguration.

## BPV 500

	0 bar - 0 p.s.i				5 bar - 72 p.s.i				10 bar - 145 p.s.i				15 bar - 217 p.s.i				20 bar - 290 p.s.i									
RPM	I/min		U.S.g.p.m.		HP		kW		I/min		U.S.g.p.m.		HP		kW		I/min		U.S.g.p.m.		HP		kW		kg	lb
400	355	93,9	2,4	1,8	352	92,9	5,4	4,0	352	92,9	9,5	7,0	348	92,0	13,6	10,0	344	91,0	17,3	12,8						
450	396	104,5	2,8	2,0	392	103,5	6,4	4,7	392	103,5	11,0	8,1	392	103,5	15,7	11,5	388	102,4	19,7	14,5						
500	435	115,0	3,1	2,3	435	115,0	7,6	5,6	431	113,7	12,2	9,0	426	112,5	17,2	12,7	426	112,5	21,7	16,0						
550	474	125,1	3,6	2,6	474	125,1	8,7	6,4	474	125,1	13,6	10,0	469	128,8	19,0	13,9	469	123,8	24,4	18,0					80	176

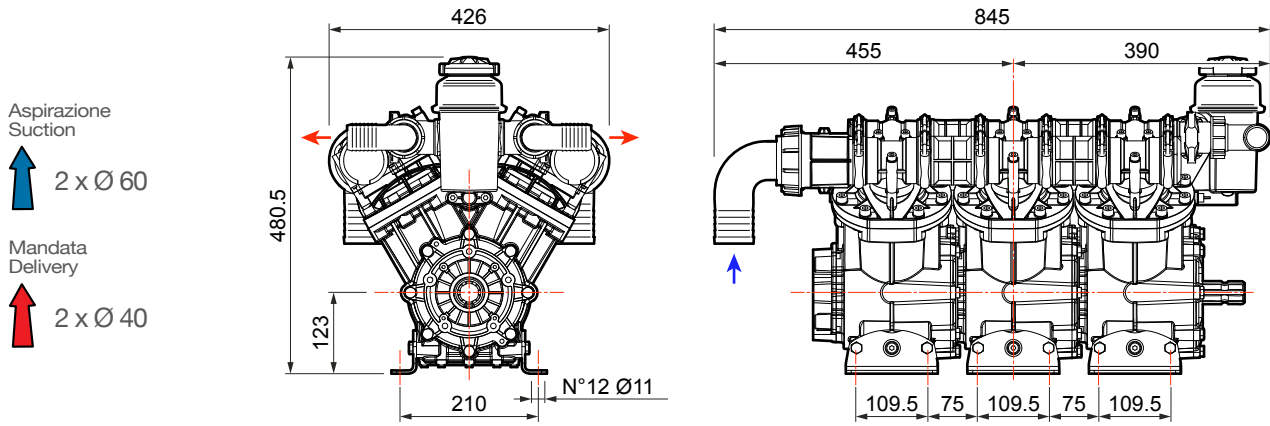

**VERSIONI STANDARD · STANDARD VERSIONS · VERSIONS STANDARD · VERSIONES ESTÁNDAR · STANDARDAUSFÜHRUNGEN**

Versioni derivate · Versions adapted · Versions dérivées · Versiones derivadas · Von der Standardversion abgeleitete Ausführungen

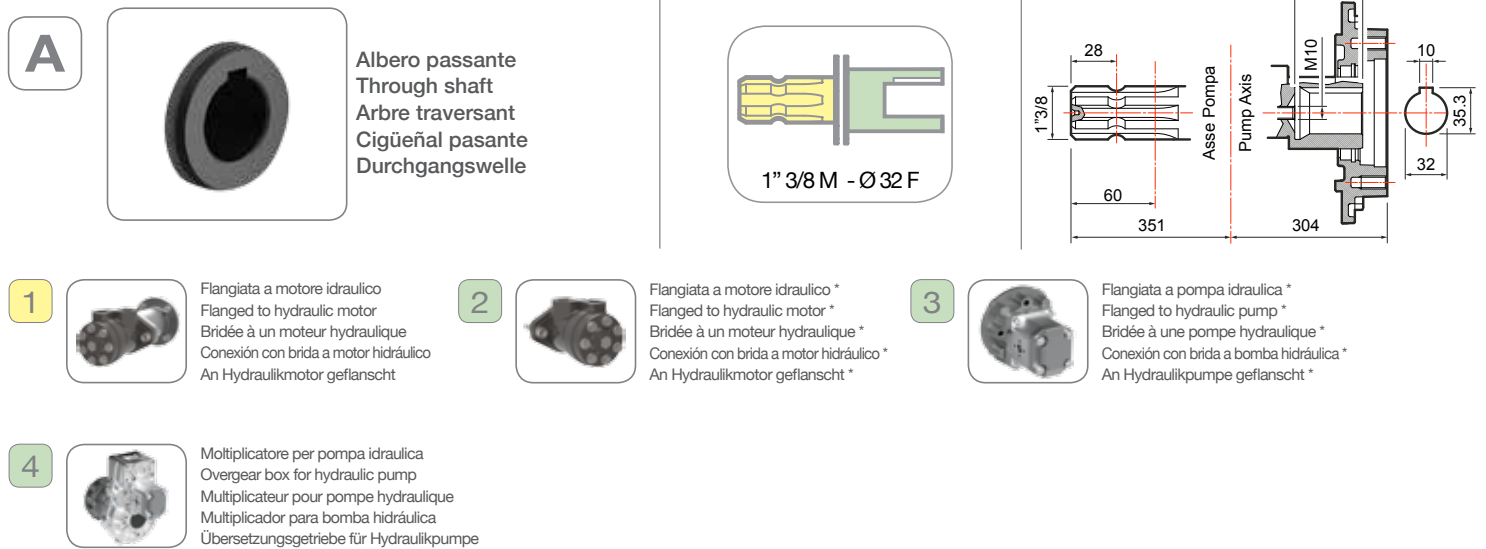

\* = flangiata diretta sulla pompa / directly flanged on the pump / bridée directement à la pompe / conexión con brida directa a la bomba / direkt an die Pumpe geflanscht

