

MP 20

Pompe a membrana a media pressione
Medium pressure diaphragm pumps
Pompes a membrane a pression moyenne
Bombas con membrana de media presion
Membranpumpen mit mittlerem druck

Configurazione a due membrane, con accumulatore di pressione.
 Parti a contatto con il liquido costruite in alluminio anodizzato e collettori interni. Attacco di mandata a gancio per applicazione diretta sulla pompa del raccordo portagomma o del gruppo di comando. Valvola di sicurezza e protezione p.d.f., a richiesta

Two membrane type, with pressure accumulator.
 Parts in contact with the liquid made of anodised aluminium and internal collectors. Hooked discharge connection for direct application of the tube connector or control unit. Safety valve and PTO protection on request

Configuration à deux membranes, avec accumulateur de pression.
 Les parties en contact avec le liquide sont en aluminium anodisé, collecteurs intérieurs. Attache de refoulement à crochet pour appliquer directement sur la pompe le raccord de tuyau ou l'ensemble de commande. Vanne de sécurité et protection prise de force sur demande

Configuración de dos membranas, con acumulador de presión.
 Partes en contacto con el líquido de aluminio anodizado y colectores interiores. Conexión de descarga por gancho para aplicación directa en la bomba del racor porta-tubo o del grupo de mando.
 Válvula de seguridad y protección t.d.f., según demanda

2-Membranen-Bauweise, mit Druckspeicher mit Flüssigkeit in Berührung kommende Teile aus Eloxal, Sammelrohre innen druckseitiger Anschluss mit Haken zum direkten Anschließen des Schlauchanschlusses oder des Steuersatzes an die Pumpe.
 Sicherheitsventil und Zapfwellenschutz auf Wunsch

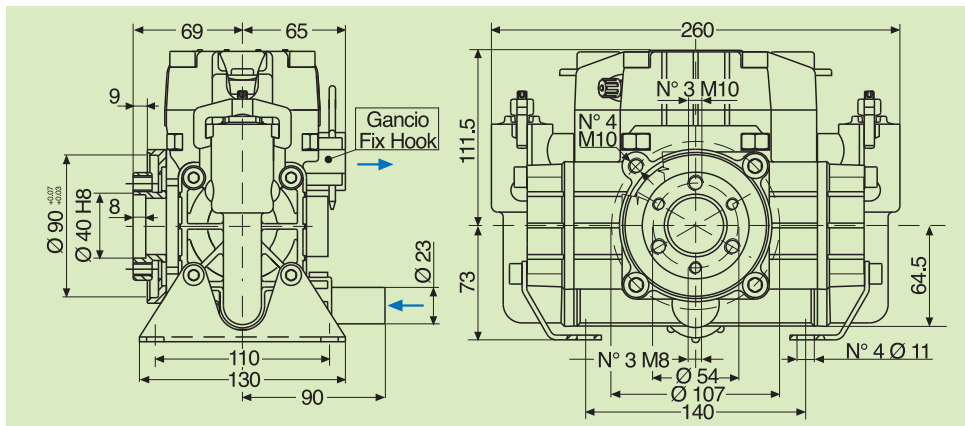

	0 bar - 0 p.s.i.				10 bar - 145 p.s.i.				20 bar - 290 p.s.i.				30 bar - 435 p.s.i.				Peso Weight Poids Peso Gewicht
	Portata Delivery Débit Caudal Foerderleistung l/min U.S.g.p.m.	Potenza Power Puissance Potencia Leistung CV kW	Portata Delivery Débit Caudal Foerderleistung l/min U.S.g.p.m.	Potenza Power Puissance Potencia Leistung CV kW	Portata Delivery Débit Caudal Foerderleistung l/min U.S.g.p.m.	Potenza Power Puissance Potencia Leistung CV kW	Portata Delivery Débit Caudal Foerderleistung l/min U.S.g.p.m.	Potenza Power Puissance Potencia Leistung CV kW	Portata Delivery Débit Caudal Foerderleistung l/min U.S.g.p.m.	Potenza Power Puissance Potencia Leistung CV kW	Peso Weight Poids Peso Gewicht						
400	16,5	4,4	0,1	0,1	14,2	3,8	0,4	0,3	14,1	3,7	0,8	0,6	14,0	3,7	1,1	0,8	6,6 14,6
450	18,0	4,8	0,2	0,1	16,1	4,3	0,5	0,4	16,0	4,2	0,9	0,7	15,9	4,2	1,3	1,0	
500	20,2	5,3	0,2	0,1	18,0	4,8	0,6	0,4	17,8	4,7	1,0	0,7	17,7	4,7	1,4	1,0	
550	22,4	5,9	0,2	0,1	19,9	5,3	0,6	0,4	19,6	5,2	1,1	0,8	19,5	5,2	1,6	1,2	

MP 20/30

Pompe a membrana a media pressione
 Medium pressure diaphragm pumps
 Pompes a membrane a pression moyenne
 Bombas con membrana de media presion
 Membranpumpen mit mittlerem druck

VERSIONE STANDARD
 VERSION STANDARD
 VERSION STANDARD
 VERSION ESTÁNDAR
 STANDARD AUSFÜHRUNG

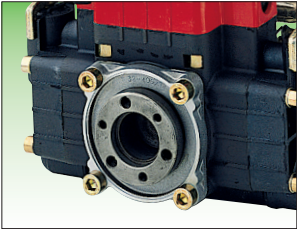

- Albero a 6 fori
- Six-Holes shaft
- Arbre percé 6 trous
- Cigüñal a seis agujeros
- 6-Loch-Welle

VERSIONI DERIVATE DA STANDARD
 VERSIONS ADAPTED FROM THE STANDARD
 VERSIONS DÉRIVÉES DE VERSIONS STANDARD
 VERSIONES DERIVADAS DE LA ESTÁNDAR — VON DER
 STANDARD AUSFÜHRUNG ABGELEITETE MODELLE

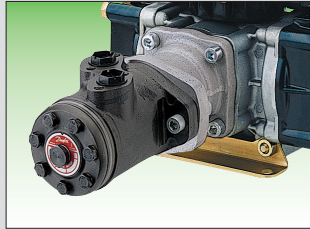

- Flangiata a motore idraulico
- Flanged to hydraulic motor
- Accouplée à moteur hydraulique
- Acoplada a motor hidráulico
- Geflanscht an hydraulischen Motor

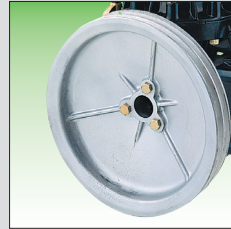

- Puleggia
- Pulley
- Poulie
- Polea
- Keilriemenscheibe

Typo Gole	Type of groove	Ø P	A
2A	172	124	
2A	247	127	
2A	292	127	

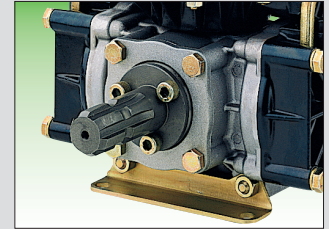
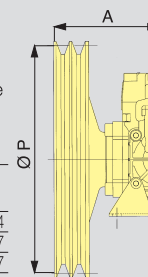

- Cardano 1" 3/8
- 1" 3/8 male PTO
- Cardan mâle 1" 3/8
- Cigüñal estriada 1" 3/8
- Für Kardan 1" 3/8

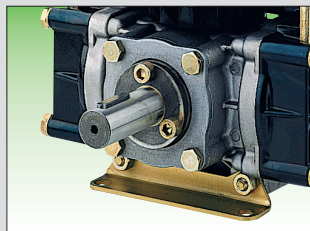
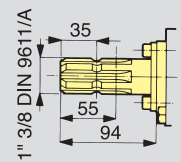

- Albero cilindrico Ø30 mm
- Solid shaft Ø30 mm
- Cardan mâle cyl. diamètre Ø30 mm
- Cigüñal cilíndrico diámetro Ø30 mm
- Zylindrische Welle Ø30 mm

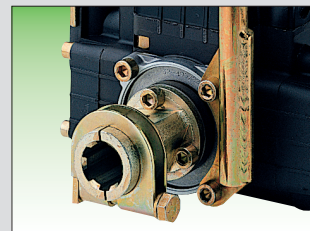
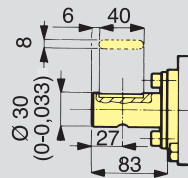

- Attacco rapido 1" 3/8
- Quick coupling 1" 3/8 spl. (female 1" 3/8 PTO)
- Accouplement 1" 3/8 femelle
- Eganche rápido 1" 3/8
- Schnellkupplung 1" 3/8

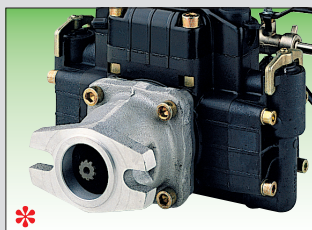
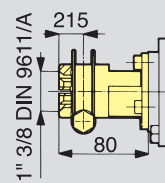

- Flangiata
- Flanged
- Bridée
- Con brida
- Geflanscht

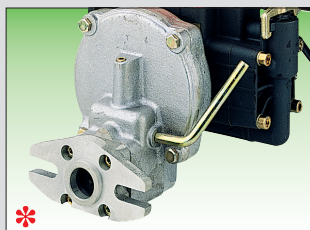

- Flangiata per motozappe
- Flanged for motor-hoes
- Bridée pour motobineuses
- Con acoplamiento para motocultores
- Anflanschung für Motorhackmaschinen

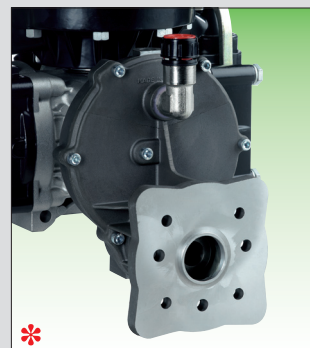

- Riduttore di giri
- Gearbox reduction
- Réducteur
- Reductor para motor
- Untersetzungsgetriebe

* Le dimensioni variano in base al tipo di applicazione.
 * Dimensions vary depending on the type of application.
 * Les dimensions varient selon le type d'application.
 * Las dimensiones varían en función del tipo de aplicación.
 * Die Abmessungen ändern sich in Abhängigkeit von der Art der Anbringung.