

SELF-PRIMING CAST IRON PUMPS

The JET series self-priming pumps combine the functional benefits of centrifugal pumps and the practical benefits of self-priming pumps. The Venturi system the pumps are fitted with guarantees optimum hydraulic efficiency and considerable pressure capacity.



- **STRONG AND RESISTANT**
- **SELF-PRIMING**
- **HIGH SUCTION CAPACITY**

Applications

- Pumping and distribution of water in domestic systems used on a continuous or intermittent basis
- Booster systems
- Washing systems, garden irrigation, fountains
- Pumping from wells or tanks

Motor

- Enclosed, externally ventilated
- Level of protection IP 44
- Class F insulation
- Single phase power supply with capacitor permanently activated and thermal protection built into the motor winding
- Three phase power supply with external protection provided by the user
- Speed of rotation 2850 rpm
- Suitable for continuous use.

Usage limitations

- Type of liquid: clean water with no suspended solids or abrasive material
- Maximum liquid temperature 50°C
- Maximum recommended suction height 8m with foot valve
- Maximum operating pressure: 6 bar (10 bar model 100-160)

DESIGN FEATURES

Component	Material	
	NEW JET	JET
Pump casing	EN GJL (ex G20) Cast iron	EN GJL (ex G20) Cast iron
Motor bracket	Aluminium	EN GJL (ex G20) Cast iron
Impeller	Technopolymer with X5 CrNi 1810 (AISI 304) Stainless steel shim ring	Technopolymer models 600-800-1000 Pressed brass alloy models 100-160-800-1000
Diffusor venturi tube and nozzle	Monobloc assembly: Technopolymer	Technopolymer
Motor shaft	X12 CrNiS 1809 (AISI 416) Stainless steel	X12 CrNiS 1809 (AISI 416) Stainless steel
Mechanical seal	Graphite	Graphite
Counterface	Ceramic	Ceramic
O-ring	NBR 70 shore	NBR 70 shore



TABLE OF HYDRAULIC PERFORMANCE

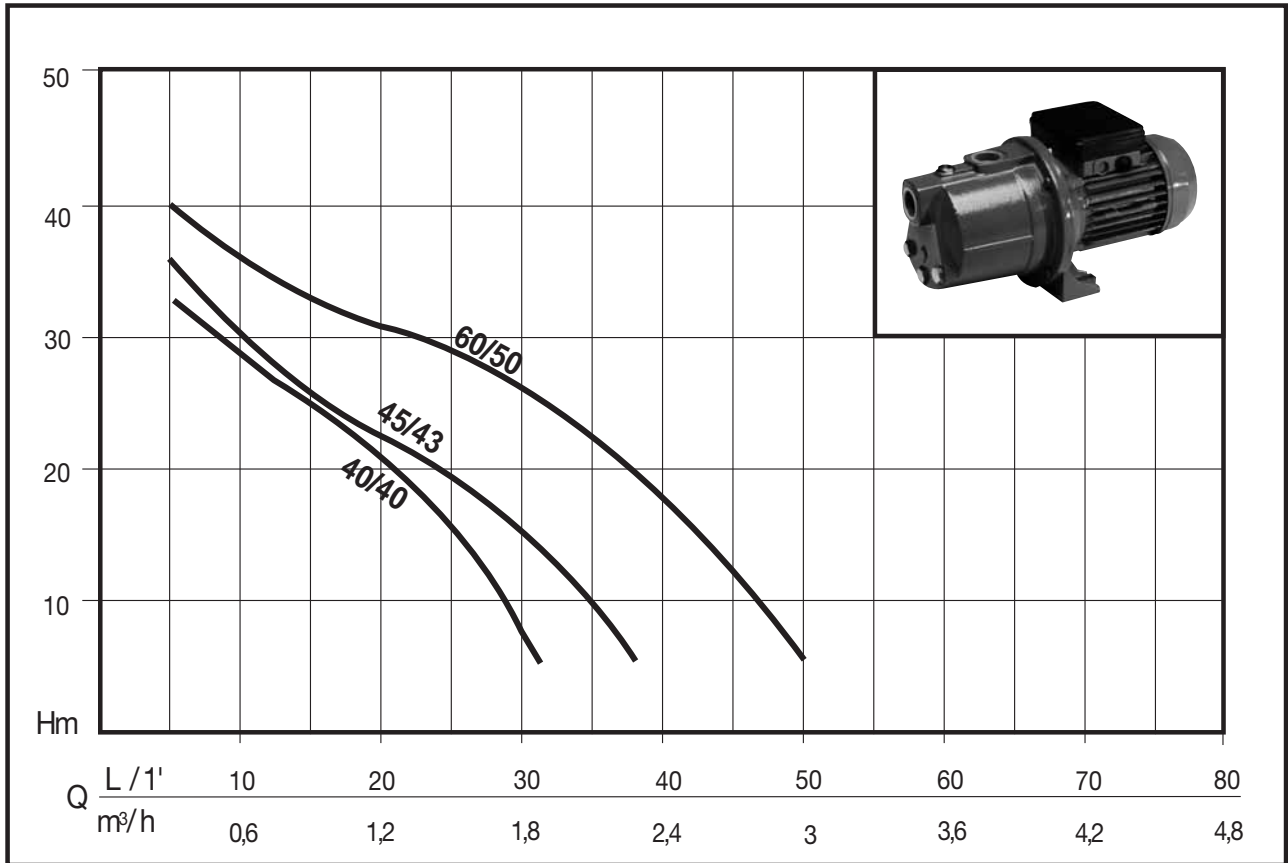

PUMP PERFORMANCE

CODE	MODEL	Nominal Power		Absorbed Power		VOLTAGE	Amp.	μF.	Q	Discharge head in meters								
		HP	kW	HP	kW					L/1'	0	10	20	30	40	50	60	70
N4176800	NEWJET 40/40 M	0,5	0,37	0,8	0,6	1 - 220 ÷ 240 V	3	6	Discharge head in meters	0	10	20	30	40	50	60	70	
N4176050	NEWJET 45/43 M	0,5	0,37	0,8	0,6	1 - 220 ÷ 240 V	3	8		0,6	1,2	1,8	2,4	3	3,6	4,2		
N4176580	NEWJET 60/50 M	0,75	0,55	1,1	0,8	1 - 220 ÷ 240 V	4	12,5		41	28	21	8					

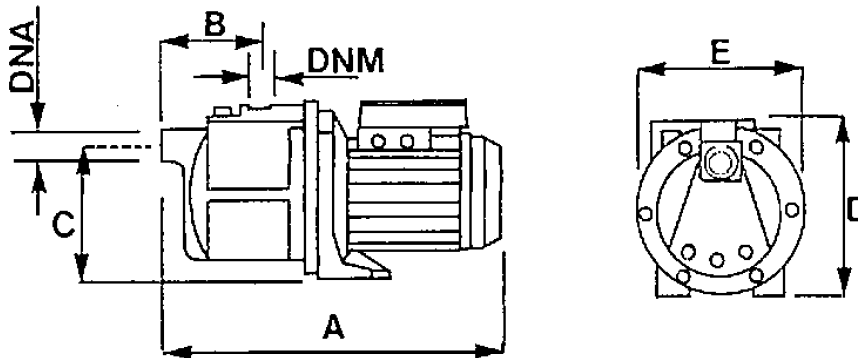
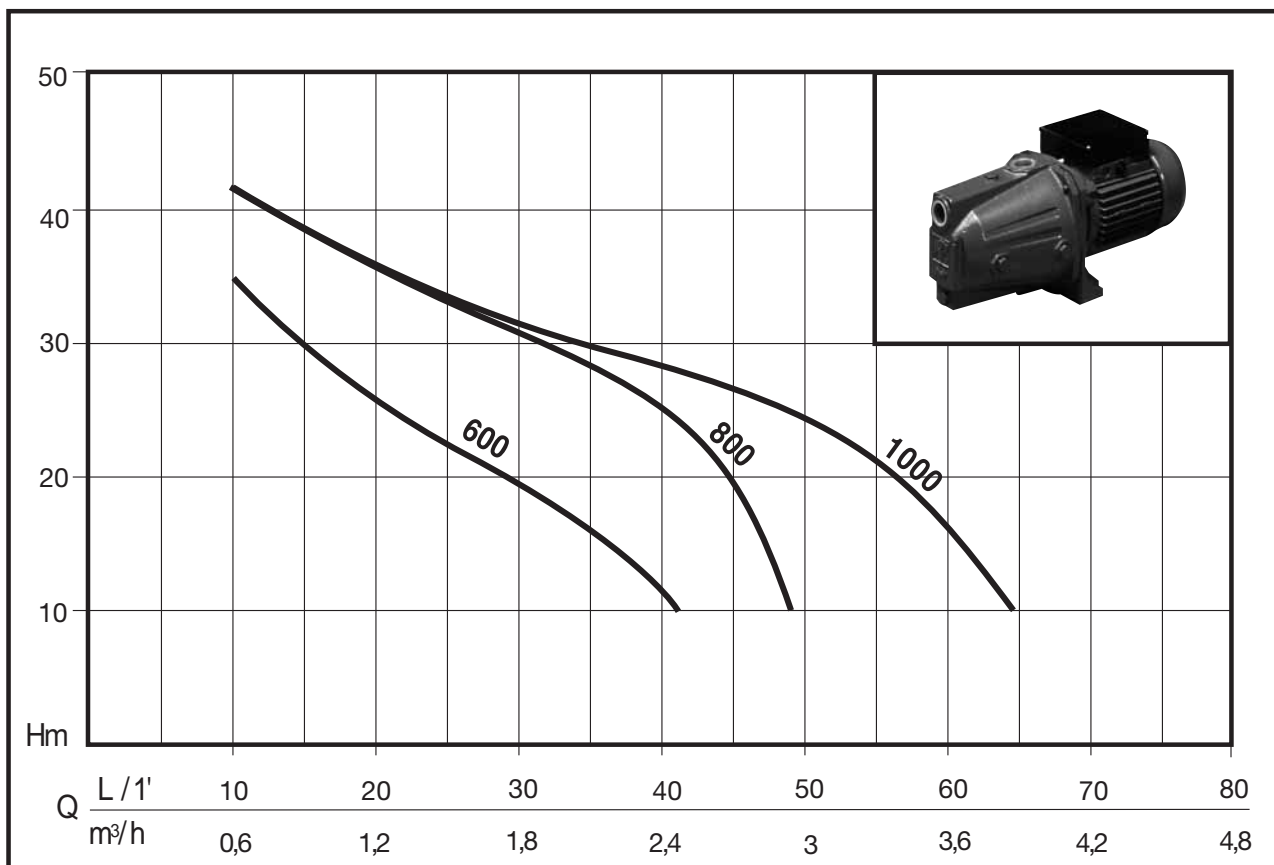

TABLE OF SIZES AND WEIGHTS

Model	Dimensions mm.							Weight
	A	B	C	D	E	DNA	DNM	
NEWJET 40/40	351	93	130	180	174	1"	1"	8,2
NEWJET 45/43	351	93	130	180	174	1"	1"	8,2
NEWJET 60/50	351	93	130	180	174	1"	1"	9



TABLE OF HYDRAULIC PERFORMANCE



PUMP PERFORMANCE

CODE	MODEL	Nominal Power		Absorbed Power		VOLTAGE	Amp.	µF.	Q	Discharge head in meters							
		HP	kW	HP	kW					0	5	20	30	40	50	60	70
N4171010 N4171020	JET 600 M JET 600 T	0,8	0,6	0,9	0,7	1 ~ 220 ÷ 240 V 3 ~ 230 ÷ 400 V	3,2 1,9-1,1	8	Discharge head in meters	42	38	25	20	11			
N4176550 N4176560	JET 800 M JET 800 T	1	0,75	1,3	1	1 ~ 220 ÷ 240 V 3 ~ 230 ÷ 400 V	4,5 3,6-2,1	12,5		48	44	36	31	27	7		
N4176860 N4176830	JET 800 M O* JET 800 T O*	1	0,75	1,3	1	1 ~ 220 ÷ 240 V 3 ~ 230 ÷ 400 V	4,5 3,6-2,1	12,5		48	44	36	31	27	7		
N4173010 N4173020	JET 1000 M JET 1000 T	1,36	1	1,5	1,1	1 ~ 220 ÷ 240 V 3 ~ 230 ÷ 400 V	5 3,8-2,2	16		49	45	36	32	28	25	15	3
N4176810 N4176820	JET 1000 M O* JET 1000 T O*	1,1	0,8	1,5	1,1	1 ~ 220 ÷ 240 V 3 ~ 230 ÷ 400 V	5 3,8-2,2	16		49	45	36	32	28	25	15	3

* Version with brass impeller

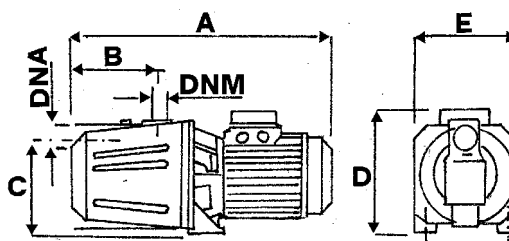
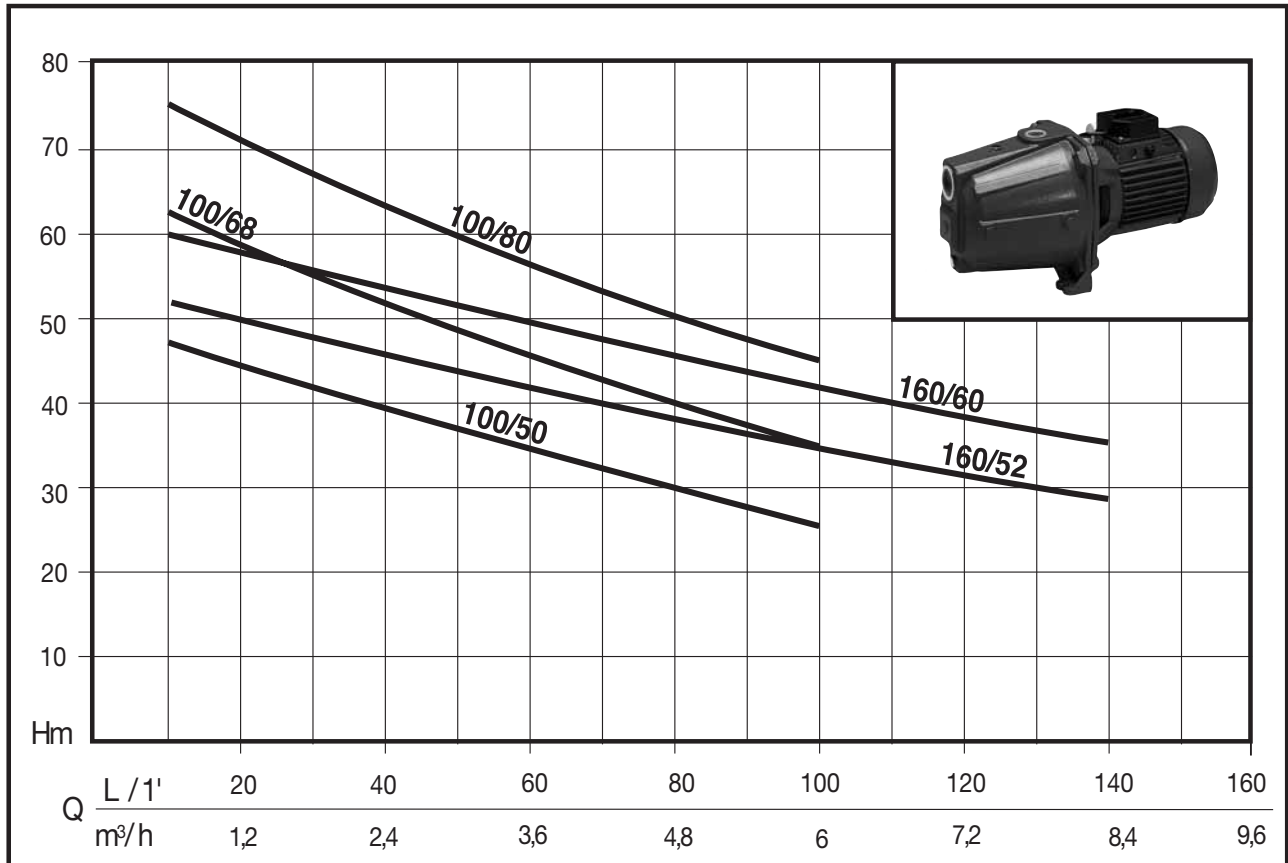

TABLE OF SIZES AND WEIGHTS

Model	Dimensions mm.							Weight
	A	B	C	D	E	DNA	DNM	kg
JET 600	400	147	160	190	182	1"	1"	13,7
JET 800	400	147	160	190	182	1"	1"	14,2
JET 1000	425	147	160	190	182	1"	1"	16,8



TABLE OF HYDRAULIC PERFORMANCE



PUMP PERFORMANCE

CODE	MODEL	Nominal Power		Absorbed Power		VOLTAGE	Amp.	μF.	Q	Discharge head in meters							
		HP	kW	HP	kW					L/1'	5	20	40	60	80	100	120
N4175010 N4175020	JET 100/50 M JET 100/50 T	1,5	1,1	2,2	1,6	1 ~ 230 V 3 ~ 230 ÷ 400 V	7,4 5-2,5	35	Discharge head in meters	0,3	1,2	2,4	3,6	4,8	6	7,2	8,4
N4175030 N4175040	JET 100/68 M JET 100/68 T	2	1,5	2,7	2	1 ~ 230 V 3 ~ 230 ÷ 400 V	10,5 7,5-4,3	40		50	45	40	35	32	27		
N4175050	JET 100/80 T	3	2,2	3,4	2,5	3 ~ 230 ÷ 400 V	8,2-4,8			65	60,5	55	48	43	35		
N4175080 N4175090	JET 160/52 M JET 160/52 T	2	1,5	2,7	2	1 ~ 230 V 3 ~ 230 ÷ 400 V	10,5 7,5-4,3	40		77	70,5	65	58	52	45		
N4175100	JET 160/60 T	3	2,2	3,4	2,5	3 ~ 230 ÷ 400 V	9,2-5,3			52	49,5	46	43	39,5	36	33,5	30
										60	58	54,5	51	47	44	40	38

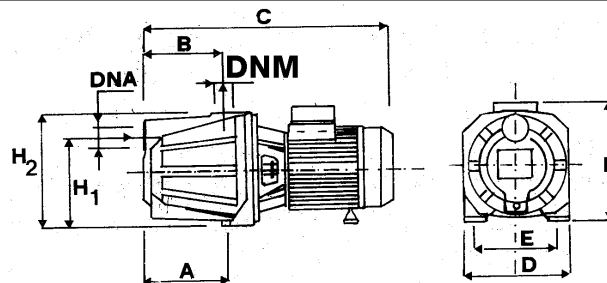

TABLE OF SIZES AND WEIGHTS

Model	Dimensions mm.										Weight kg
	A	B	C	D	E	F	H ₁	H ₂	DNA	DNM	
JET 100/50	180	157	500	220	180	235	170	227	1" 1/2	1"	27
JET 100/68 - 160/52	180	157	500	220	180	235	170	227	1" 1/2	1"	29
JET 100/80 - 160/60	180	157	500	220	180	235	170	227	1" 1/2	1"	31